

UFCL-limiter

MV Fault Current Limiter



UFCL-limiter

The fastest limiting and switching device in the world



The UFCL-limiter, a fault current limiter based on pyrotechnic technology, is a technological answer to the problem of higher levels of short circuit current where system augmentation takes place but replacing of whole protection switchgear is not feasible.

Faults in electrical power systems are inevitable. Apart from the damages in the vicinity of the fault - e.g. due to the effects of an electric arc - the fault currents flowing from the sources to the location of the fault impose high dynamical and thermal stresses on equipment like bus-bars, transformers, and switchgears. The circuit-breakers further have to be capable of (selectively) interrupting the currents associated.

But, a growth in the generation of electrical energy and an increased interconnection of the networks lead to higher fault currents. Especially, the continuous growth in the generation of electrical energy has the consequence that networks approach or even exceed their limits with respect to the short-circuit current withstand capability. Therefore, there is a considerable interest in devices which are capable of limiting fault currents. A fault current limiter can trip at the very early stage of first rise and limit the first peak of the fault current passing through it.

The use of UFCL-limiters allows equipment to remain in service even if the prospective fault current exceeds its rated peak and short-time withstand current and in case of circuit breakers also its rated short-circuit making and breaking current. Replacement of equipment can be avoided or at least shifted to a later date. In case of newly planned networks UFCL-limiters allow the use of equipment with lower ratings which renders possible considerable cost savings. In case of newly planned networks UFCL-limiters allow the use of equipment with lower ratings which renders possible considerable cost savings.

How can UFCL-limiter protect the system?

Sometimes, UFCL-limiter is the only solution

As shown in Figure 1 below, the UFCL-limiter is installed in the bus-tie section and is series-connected to the bus coupling circuit-breaker (CB). In the event of a short-circuit in the outgoing feeder, the prospective short-circuit current flowing through the outgoing feeder CB (I_k'') may reach 80kA_{rms} , which is equivalent to a peak current of 200kA_p . This exceeds the ratings of the CB (40kA_{rms} and 100kA_p). In other words, the CB is unable to provide protection against this high peak short-circuit current and the operation speed of the CB is too slow. This will lead to serious mechanical and thermal stress and eventually equipment failure.

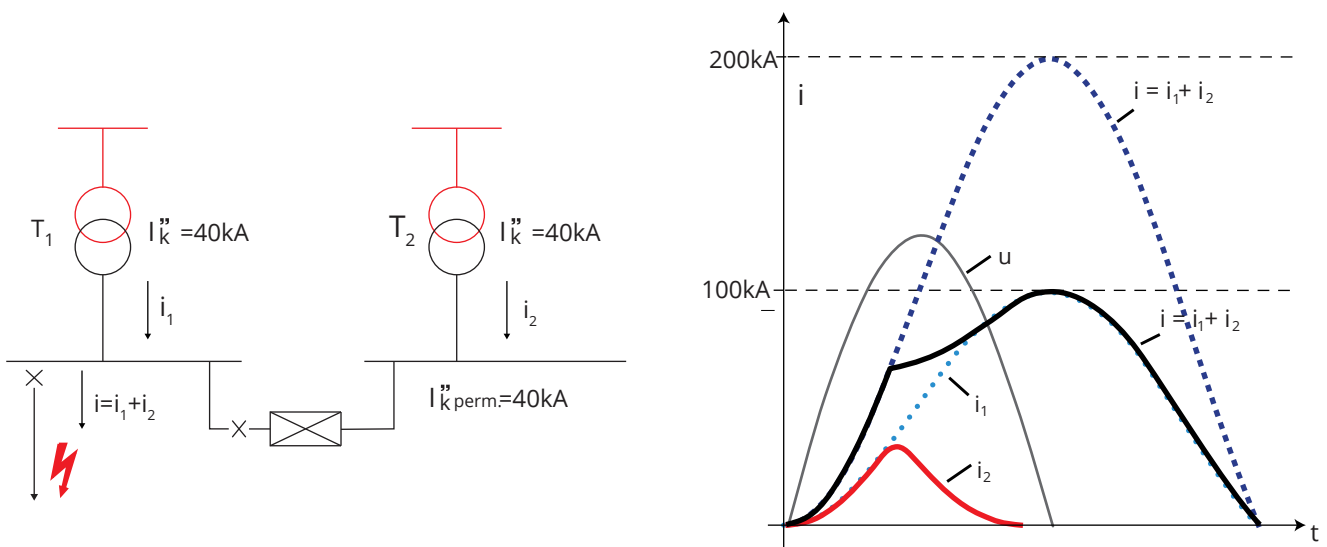

Figure-1

However, thanks to the high operation speed and current limiting capabilities of the UFCL-limiter, it is possible to resolve this issue without upgrading all the equipment in the system. By installing the UFCL-limiter on the strategic position of the bus-tie, the short-circuit current i_2 contributed by T_2 is limited at the rise of the first cycle and interrupted before the prospective current i_2 reaches its peak. The total (peak) short-circuit current flowing through the CB of the fault circuit is then kept below 100kA_p ($i_1 + i_2 < 100\text{kA}_p$), which is the rated peak withstand current of the CB. Therefore, the CB can withstand the fault current and trip to clear the fault safely.

In comparison with complex conventional solutions, the UFCL-limiter has both technical and economic advantages when used in transformer or generator feeders, in switchgear sectionalizing and connected in parallel with reactors. There is no need for customers to upgrade all the switchgear, bus-bars cables, etc.

The advantages of the use of a UFCL-limiter in a network are:

- Reduction of the short-circuit current of the system (compared to the short-circuit current with closed tie circuit breaker)
- Reduction of voltage sags and flicker due to the lower total source impedance
- Reduction of harmonics due to the lower total source impedance
- Higher system availability due to the parallel connection of the feeding generators and transformers
- Higher loads possible in a sub-system (higher than the ratings of the feeding generators and transformers in that sub-system)



UFCL-limiter solves your problems

Reliable, proven, cost-effective

Features

- Conform to CIGRE Technical Brochure 239, 497
- Conform to IEEE Std C37.302™-2015
- Conform to IEC 62271-1 and IEC 60282-1
- Indoor and outdoor application
- Mounted in loose type as well as a metal-clad switchgear panel
- Durable against harsh climate, land or offshore
- Easy to be installed and minimal maintenance
- High reliability proved in lots of installations

Benefits

- Reduces substation cost
- Solves short-circuit problems in new substations and substation extensions
- Optimum solution for interconnection of switchboards and substations
- In most cases the only technical solution
- The peak short-circuit current will never be reached
- The short-circuit current is limited at the very first current rise

How does UFCL-limiter work?

Cutting-edge pyrotechnic technology

Principle

The interrupting device of UFCL-limiter, also known as current limiter inserts, consists of two parallel components:

- An ultra-fast interrupter - main conductor
- A special current limiting fuse - parallel fuse

Under normal operation, the load current flows through the main conductor. When the tripping signal is triggered, the main conductor will be opened in a very short time, then the fault current is commutated to the parallel fuse. The fuse then limits and breaks the instantaneous current within the first half cycle.

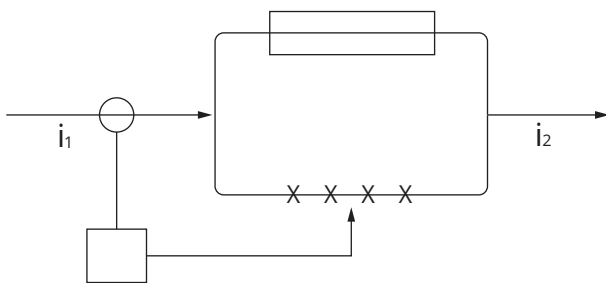

Figure-2

Current transformer

A current transformer is installed in the insulating tube with an ultra-fast interrupter, which measures the current flowing through UFCL-limiter continuously and transmit the real-time values to the tripping unit. Rogowski type current transformer has remarkable features of extremely high over-current factor and high precision.

Pyrotechnic switch

The pyrotechnic switch or an ultra-fast interrupter is designed as a bursting bridge, that contains multiple charges. These charges are triggered by a tripping signal and the ultra-fast interrupter opens at the rupture points rapidly.

Special current limiting fuse

Current limiting fuse is used to limit and break the short-circuit current. The over-voltage level will not exceed the standard IEC 60282-1.

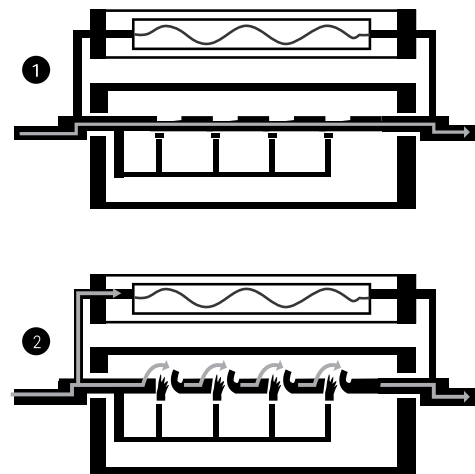

Figure-3

Tripping unit

A tripping unit monitors and evaluates the current supplied by the tripping current transformer continuously. It determines whether tripping is necessary or not. The three tripping units (one per phase) work independently of each other.

Tripping criteria are as follows:

- The instantaneous current value and
- The rate of current rise

UFCL-limiter's components

We put safety first

Bursting bridges along rectangular main conductors, multi-charge structure make redundancy.

Tripping units are located on the high-voltage side and built-in anti-interference units to reduce electromagnetic interference and enhance reliability.

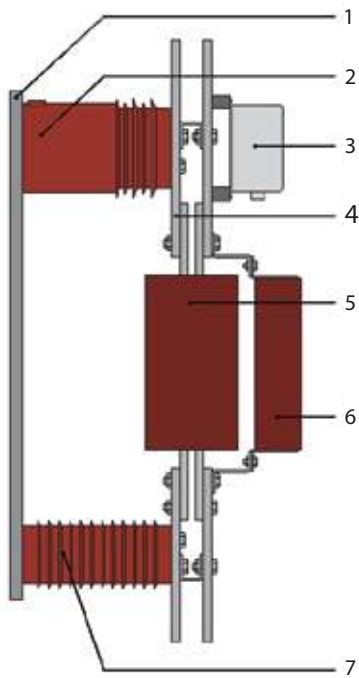

Figure-4: UFCL-limiter 12kV, 4000A (1 phase)

1. Base plate
2. Isolation transformer
3. Tripping unit
4. Bus-bar
5. Ultra-fast Interrupter
6. Special current limiting fuse
7. Insulator

Monitoring and indication unit

The monitoring and indication unit continuously monitors the basic function of the UFCL-limiter and provide local and remote indication for:

- Trip signal for each phase (three in total);
- Monitoring of readiness for operation;
- Monitoring of the supply voltages.



Figure-5 Monitoring and indication unit

Isolation transformer

An Isolation transformer provides auxiliary voltage for the tripping unit, the auxiliary voltage is taken from power unit installed in the monitoring and indication unit. Besides it is also the channel for the tripping unit to output the tripping signal to indication unit.



UFCL-limiter in loose equipment supply

Easy to be installed and maintained

The UFCL-limiters for standard applications of indoors and outdoors in loose type remove space, can be mounted without switchgear panels, the difference between the outdoor and indoor products, is that the components of outdoor products are all for the application of outdoor use, special measures are taken for the function of weather resistance.

Technical data

Rated voltage	kV	7.2	12	17.5	24	36	40.5
Rated current	A	1250 ~ 6300		1250 ~ 4000		1250 ~ 3150	
Rated frequency	Hz	50/60					
Rated short-circuit breaking current	kA _{rms}	Up to 200					
Rated power-frequency withstand voltage	kV	20	28	38	50	70	95
Rated lightning impulse withstand voltage	kV	60	75	95	125	170	185
Tripping time	ms	< 1					
Total operating time	ms	< 10 ¹⁾					
Peak current limiting ratio	%	15 ~ 50					
Rated auxiliary voltages	V	DC 110, 220; AC 110, 220, 230					

¹⁾The total operating time is based on the default frequency of 50Hz. In case of 60Hz the total operating time is less 8 ms and you must inform during the inquiry or ordering the goods.



UFCL-limiter switchgear

Customization is available

The UFCL-limiters are also available as fixed-mounted equipment in a metal-clad switchgear panel.

The power parts of UFCL-limiter and the three tripping units are fixed-mounted in HV compartment of the panel. The monitoring and indication unit is installed in the LV compartment of the panel.

For all fixed-mounted UFCL-limiters, the electrical data is the same as for loose equipment supply. Weight and dimensions can be provided on request.

Technical data

Rated voltage	kV	7.2	12	17.5	24	36	40.5
Rated current	A	1250 ~ 6300		1250 ~ 4000		1250 ~ 3150	
Rated power-frequency withstand voltage	kV	20	28	38	50	70	95
Rated lightning impulse withstand voltage	kV	60	75	95	125	170	185
Rated frequency	Hz	50/60 ¹⁾					
Rated auxiliary voltages	V	AC 220, 230					

¹⁾ The default rated frequency is 50Hz, please inform if it is 60Hz during the inquiry or ordering goods.

* If you want to know more about dimensions of the switchboard, please contact with us.

Applications

Flexible solutions ensure an interruption-free power supply

UFCL-limiters in system interconnections

UFCL-limiters are frequently used in interconnections between systems or in bus sections which would not be adequately short-circuit proof when connected by a circuit-breaker. Each sub-system should have at least one incoming feeder, so that the power supply to each sub-system can be maintained on tripping of the UFCL-limiter. There numerous advantages for the operation under normal conditions of bus sections.

Connected by UFCL-limiters:

- Reduction of the series network impedance. The voltage drops caused by load
- Improvement of the current distribution at the feeder transformers
- The load dependent losses of the feeder transformers are reduced
- Increased reliability of the power supply

On failure of one feeder transformer, the load is taken over by the other feeder transformers without current interruption. On the other hand, the cost of required new switchboard with higher short-circuit capacity will be saved.

If a short-circuit occurs within a system or in an outgoing feeder, the UFCL-limiter trips at the first rise of the short-circuit current and splits the bus-bar into two sections before the instantaneous current reaches an impermissible high level.

After tripping of the UFCL-limiter, the short-circuit is only fed by the transformer in the part of the system affected by the short-circuit. The short-circuit current is now selectively interrupted by the circuit-breaker. A remarkable advantage of the use of an UFCL-limiter is that the voltage in the part of the system not affected by the short-circuit only drops for a fraction of a millisecond so that even sensitive loads (e.g. data centers) remain protected from drops in the system voltage.

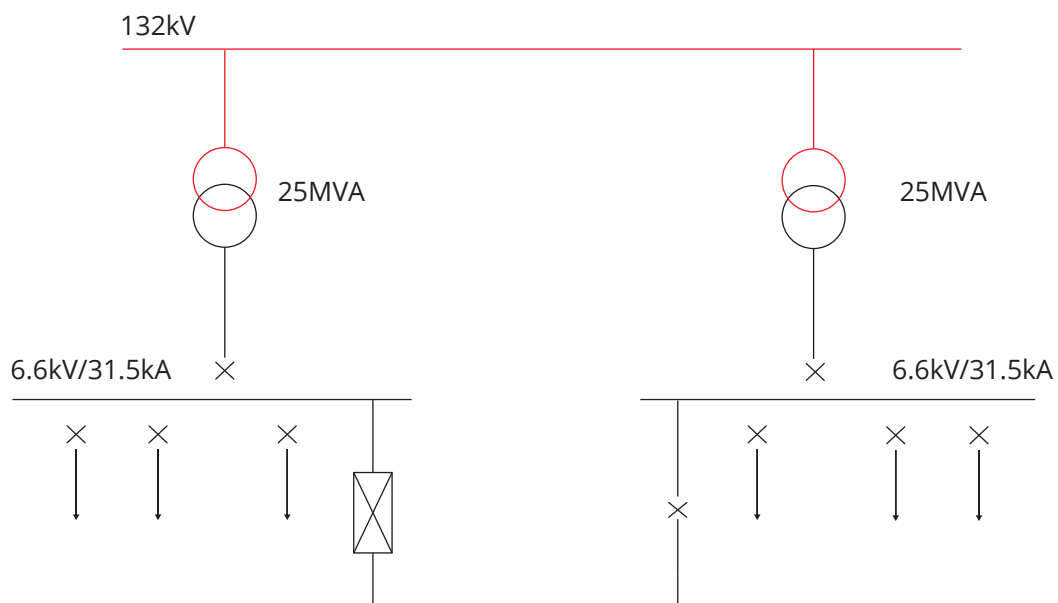

Figure-6

Applications

Flexible solutions ensure an interruption-free power supply

UFCL-limiter installed in generator feeders

When a new generator is connected to the grid, the additional short-circuit current from generator leads to the prospective short-circuit current in the utility network being exceeded. The best technical solution – and mostly the only one – is the installation of UFCL-limiter in the interconnection with the public utility network, this application's advantages are:

- Generator can be connected regardless of the short-circuit capability of the system
- Existing bus-bar and cable systems don't have to be changed
- No need of expensive generator breaker

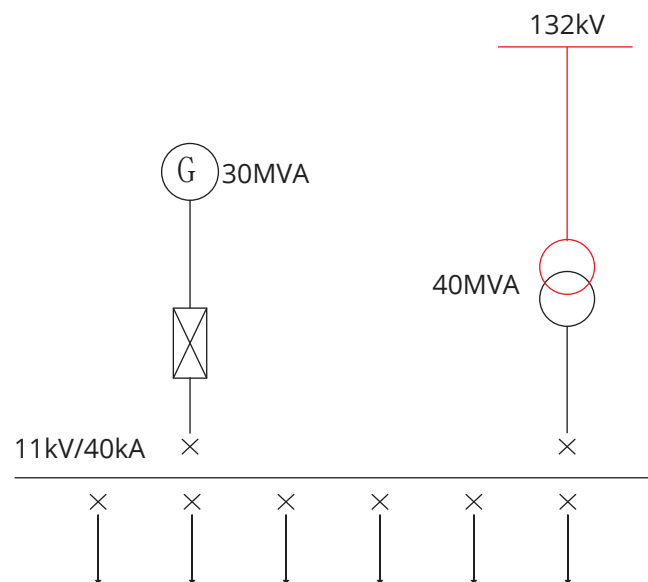

Figure-7

UFCL-limiter in parallel with reactors

UFCL-limiter is connected in parallel with a reactor (Figure 8). If a short-circuit occurs behind the reactor, the UFCL-limiter trips at the first rise of short-circuit current and the current commutates to the parallel reactor, which then limits the short-circuit current to the permissible level. For normal operation, the UFCL-limiter bypasses the reactor coil, this application's benefits are:

- Avoids current dependent copper losses and the associated operating costs of the reactor
- Avoids current dependent voltage drop at the reactor, which frequently causes major difficulties on start-up of big motors
- Control problems with the generator

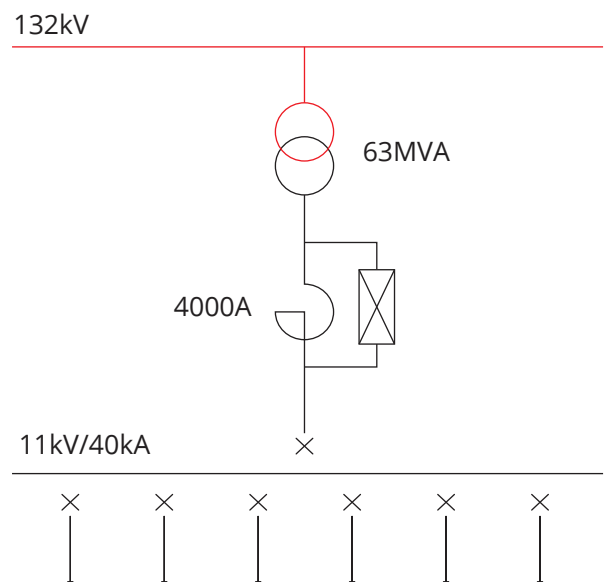

Figure-8

Selective tripping and applications

Selective tripping based on the closely related nodes

Expansion of the existing system

As shown in Figure 9, When interconnecting the existing system with a new system or connecting a customer's power generation system with the public utility, the short-circuit current level may exceed the permissible ratings of the existing system, but not the new system. Our fault current limiter, the UFCL, not only can solve the short-circuit current problem, but it can also realize directional tripping and avoid unnecessary tripping, that's is, a selective tripping. Function with the addition of a selective tripping unit (STU) based on the closely related node technology (CRNT):

- When a short-circuit fault occurs on bus A, and the prospective short-circuit current exceeds its permissible rating, i.e. $I_k'' > I_{k,perm.1}$, the UFCL will trip to protect bus A and its subsystem
- When a short-circuit fault occurs on bus B, and the prospective short-circuit current remains below its permissible rating, i.e. $I_k'' > I_{k,perm.2}$, the UFCL will not trip

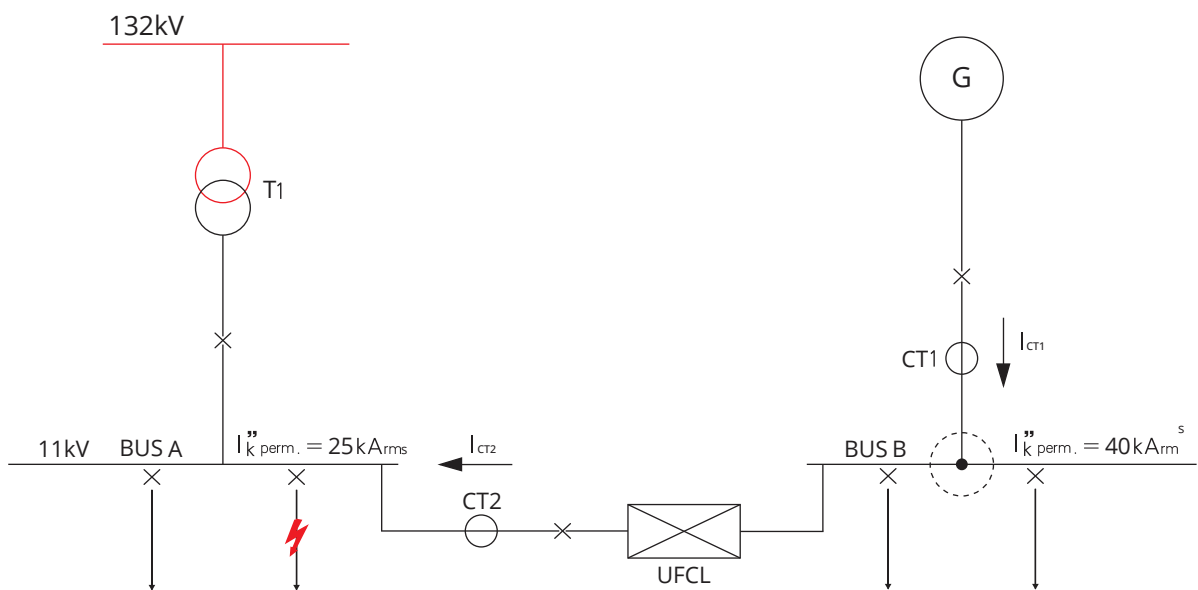

Note:  Closely related nodes

Figure-9

Parallel operation of multiple sources

As shown in Figure 10, Industries often use parallel operation of multiple power sources to improve power supply reliability, load balance, and stability. However, this can lead to short-circuit current levels exceeding the permissible ratings. Such an operation requires multiple FCLs to limit the short-circuit current and must trip selectively based on fault location. This can be achieved with STU based on CRNT, that is:

- When a short-circuit fault occurs on bus A and the prospective short-circuit current level exceeds its permissible rating, only UFCL1 will trip to protect bus and its subsystem
- When a short-circuit fault occurs on bus B and the prospective short-circuit current level exceeds its permissible rating, UFCL1 and UFCL2 both will trip bus and its subsystem
- When a short-circuit fault occurs on bus C and the prospective short-circuit current level exceeds its permissible rating, only UFCL2 will trip to protect bus C and its subsystem

Selective tripping and applications

Selective tripping based on the closely related nodes

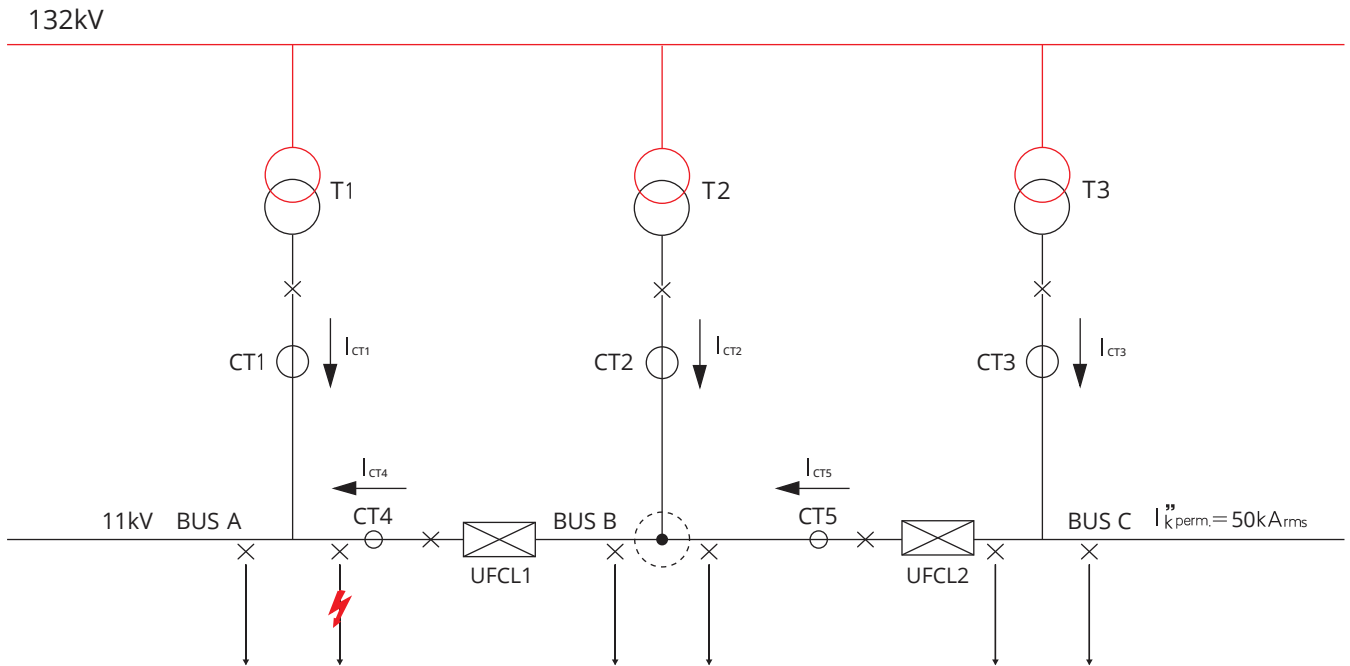

Note:  Closely related nodes

Figure-10

The coordination between selective tripping unit (STU) and tripping unit (ITU3)

The STU is a controller used when selective tripping is required for a system. The STU uses the current data from the nearby current transformers to realize the quick identification of the faulty section based on current direction and magnitude.

This unit needs to work in conjunction with the tripping unit ITU3, its criteria form an "AND" logic with the criteria of the ITU3 (the instantaneous current and the rate of current rise). Once the criteria of the STU are met, the STU will send an enabling signal to the corresponding FCL's ITU3. The corresponding FCL(s) will trip. Other FCLs that didn't receive the enabling signal from the corresponding STU will not trip even the setting value of their ITU3 has been met.

Technical services and support

High-quality products need perfect service, UFCL-limiter can be life-long technical supported

Technical consulting

Our specialists have long-term experience and knowledge of the electrical systems, according to the needs we can provide customers with system assessment and help engineering companies to achieve the design of high-quality short-circuit protection. If you want to make your system more efficient and safe, INNOVIT will always be your trusted adviser.

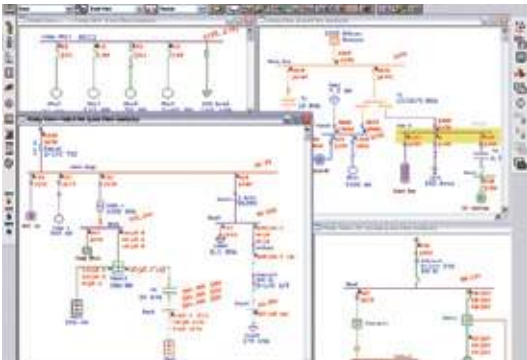

Spare parts

We provide our customers with the fastest and most reliable spare parts service. We use common spare parts inventory and optimized logistics chain to provide high-quality and original spare parts to help you improve the reliability of equipment and system operation, to minimize downtime and revenue loss caused by the loss of production operation.



Installation and commissioning

For optimum performance, the UFCL-limiters as critical system equipment must be installed and commissioned by experienced service engineer. Our service engineers provide professional installation commissioning services to ensure the safe and stable operation of systems and equipment. Our services can meet your installation requirements for the system or equipment, including: installation inspection, functional and system testing of the equipment, commissioning, acceptance testing, etc.

Regular testing and maintenance

We provide manufacturer-level preventive maintenance and advanced predictive diagnostics for the supply to ensure your equipment meets all standards and guarantees safe operation. During the contract period, customers can also get a variety of service commitments, such as 24-hour hotline, emergency spare parts supply and rapid on-site repair. In addition, flexible expert support is available for you to choose from, such as periodic inspections, system security assessments, and more.



Xi'an Innovit Electric Co., Ltd.

No. 190 of Western Avenue, Xi'an, China

www.innovit.com.cn

sales@innovit.cn

© INNOVIT 2010-2025,

Edition 5, UFCL-limiter, This information is subject to change without notice.